

Rapid Palatal Expander (RPE)

To Activate the Expander:

1. Insert the wrench near the upper teeth
2. Have the patient open wide
3. Swing the wrench down to touch the lower teeth
4. Remove the wrench from the patient's mouth
5. Rotate the wrench before the next swing

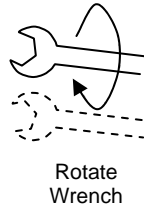
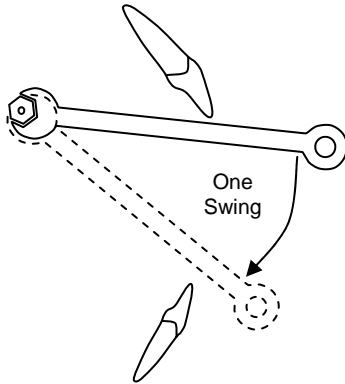

Please don't let the patient activate the expander

Activation Instructions:

**3 swings per night
until you see 4 lines**

(don't forget to rotate the
wrench between swings)

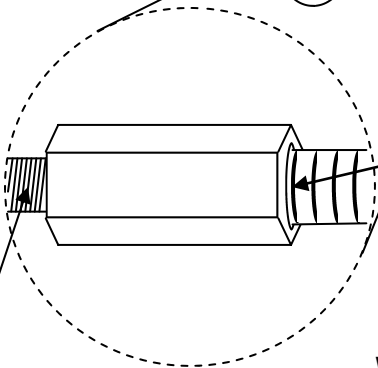
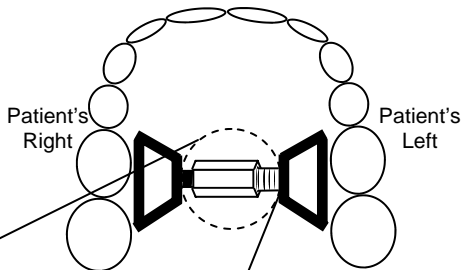

Stop when the 4th
line appears on the
patient's **left** side



Ignore the threads
on the patient's
right side

**With proper activation,
you should see about
one line per week**